

Pneumatic Drive Bellows Pump & Auto Damper

HJS K-Series ベローズポンプとダンパー HJS K-Series Bellows Pump & Auto Damper



高品質及び耐久性 High quality and Durability

- 流量安定性、広範囲な温度適用及び耐久性
Flow stability, Wide range of operating temperature and Durability



特別な利点 Special advantages

- 短い供給納期 (*Short lead delivery times*)
- 既存ポンプの代替性 (*Replaceability of existing pumps*)
- 価格競争力 (*Price competitive*)



簡単なメンテナンス Easy maintenance

- 低メンテナンスコスト費用 (*Low cost for maintenance*)

KP-30MC & KP-60MC

□ 中温・常温兼用ポンプ (Bellows Pump)

Medium • Room-Temperature combined Bellows pump

KP-60MC



KP-30MC

適用範囲 (Operating temperature)
10°C~100°C

最大流量 (Max Flow rate)
30L/min & 60L/min

価格競争力
Price competitive

□ 流量 Pump Performance Curve

KP-30MC

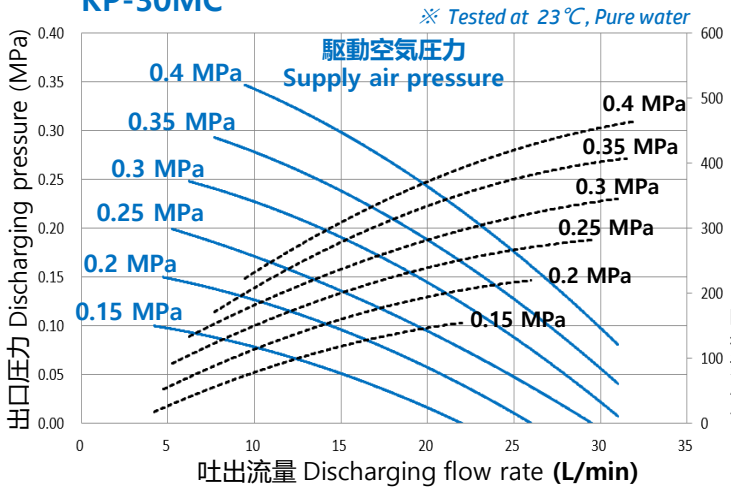

試験条件 Test conditions

- Supply air pipe size : Rc 3/8" (PT) Port (Tube O.D10 X I.D8 X 2M)
- Liquid pipe size : 3/4" Port (Tube O.D19 X I.D16)
- Test liquid : Pure water, 23°C

KP-60MC

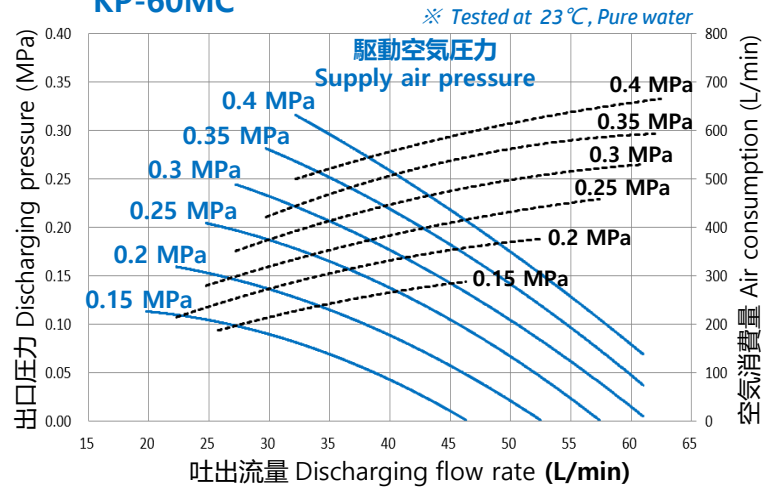

試験条件 Test conditions

- Supply air pipe size : Rc 1/2" (PT) Port (Tube O.D12 X I.D10 X 2M)
- Liquid pipe size : 1"Port (Tube O.D25 x I.D22)
- Test liquid : Pure water, 23°C

□ 駆動空気圧力範囲 Driving Air Pressure Range

KP-30MC
KP-60MC

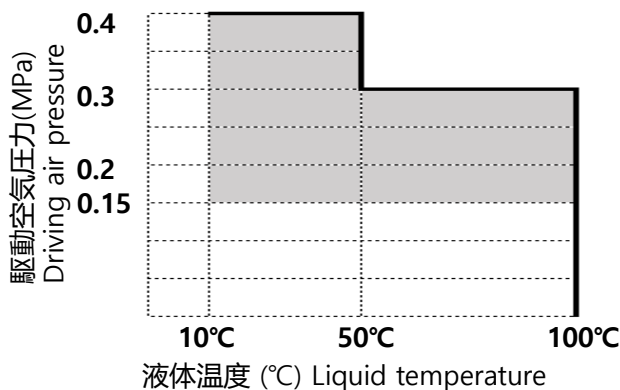

KP-30MC & KP-60MC

□ 規格 Standard Specifications

Items / Models		KP - 30MC			KP - 60MC				
最大吐出流量(L/min) Max. discharging flow rate		(*Note.1) 30 L/min			(*Note.1) 60 L/min				
ストローク当たり流量 Flow rate per stroke (L/stroke)		(*Note.2) 0.40 L/stroke			(*Note.2) 0.86 L/stroke				
液体温度の使用範囲 (°C) Temperature range of liquid		10 ~ 50°C	51 ~ 100°C	/		10 ~ 50°C	51 ~ 100°C		
駆動空気圧力範囲(MPa) Driving air pressure range		0.15 ~ 0.4 MPa	0.15 ~ 0.3 MPa			0.15 ~ 0.4 MPa	0.15 ~ 0.3 MPa		
最大許容ストローク速度 Max allowable Stroke speed		Max 75 stroke/min			Max 70 stroke/min				
駆動空気供給接続ポート Air supply inlet ports		2-Rc 3/8" (PT)			2-Rc 1/2" (PT)				
液体接続ポート Liquid connection ports		PTFE 3/4" (O.D 19 x I.D16mm)			PTFE 1" (O.D 25 x I.D 22mm)				
液体接触材質 Liquid contact materials		PTFE, PFA							
周囲環境温度範囲 Ambient temperature		5 ~ 50°C							
近接 センサー スイッチ Proximity switch	出力形態 Output type	NPN Output (N.O. mode)							
	パワー Power supply	DC 10~30V							

*Note.1) 最大吐出流量は室温で純水で、最大ストローク速度基準で測定

*Note.2) 1 ストローク (1 stroke) : 1 回往復 (1 reciprocating motion)

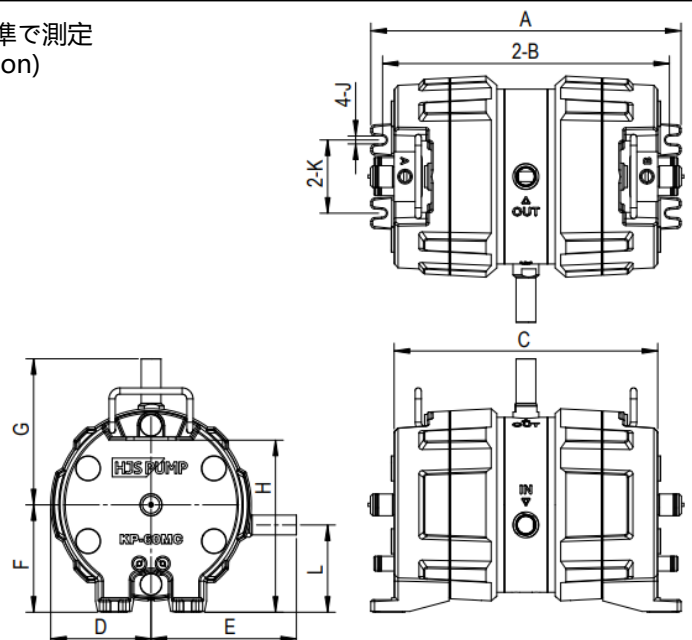
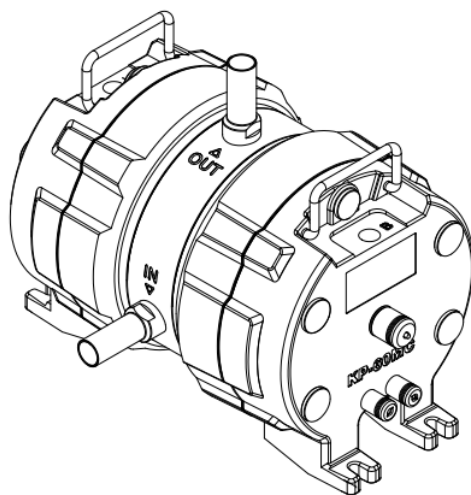

Models	A	B	C	D	E	F	G	H	J	K	L	Liquid in/out ports	Air supply ports	Weight
KP-30MC	386	360	326	108.5	163.5	119.0	165.5	182.0	10	80	95	3/4"	Rc 3/8" (PT)	20 Kg
KP-60MC	399	373	339	129.2	187.0	137.8	187.5	220.8	10	94	112	1"	Rc 1/2" (PT)	28 Kg

KP-30H & KP-60H

□ 高温・中温・常温兼用ポンプ (Bellows Pump)

High • Medium • Room-Temperature combined Bellows pump

KP-60H



KP-30H

適用範囲 (Operating temperature)
10°C~180°C

最大流量 (Max Flow rate)
30L/min & 60L/min

便利な在庫管理
Easy stock management

□ 流量 Pump Performance Curve

KP-30H

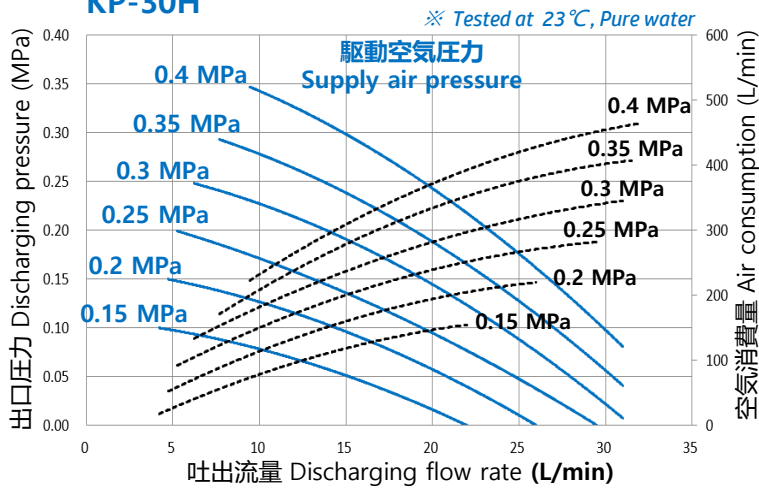

KP-60H

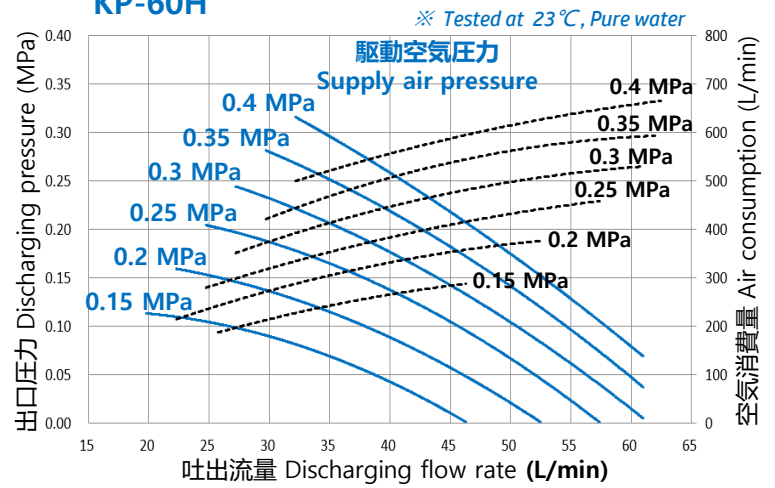

試験条件 Test conditions

- Supply air pipe size : Rc 3/8" (PT) Port (Tube O.D10 X I.D8 X 2M)
- Liquid pipe size : 3/4" Port (Tube O.D19 X I.D16)
- Test liquid : Pure water, 23°C

試験条件 Test conditions

- Supply air pipe size : Rc 1/2" (PT) Port (Tube O.D12 X I.D10 X 2M)
- Liquid pipe size : 1"Port (Tube O.D25 x I.D22)
- Test liquid : Pure water, 23°C

□ 駆動空気圧力範囲 Driving Air Pressure Range

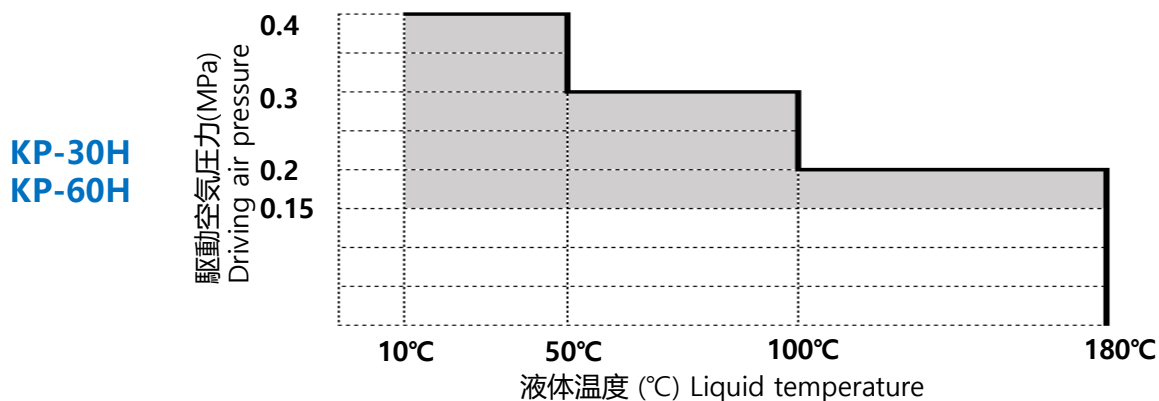

KP-30H & KP-60H

□ 規格 Standard Specifications

Items / Models		KP - 30H			KP - 60H		
最大吐出流量(L/min) Max. discharging flow rate		(*Note.1) 30 L/min			(*Note.1) 60 L/min		
ストローク当たり流量 Flow rate per stroke (L/stroke)		(*Note.2) 0.40 L/stroke			(*Note.2) 0.86 L/stroke		
液体温度の使用範囲 (°C) Temperature range of liquid		10 ~ 50°C	51 ~ 100°C	101 ~ 180°C	10 ~ 50°C	51 ~ 100°C	101 ~ 180°C
駆動空気圧力範囲(MPa) Driving air pressure range		0.15 ~ 0.4 MPa	0.15 ~ 0.3 MPa	0.15 ~ 0.2 MPa	0.15 ~ 0.4 MPa	0.15 ~ 0.3 MPa	0.15 ~ 0.2 MPa
最大許容ストローク速度 Max allowable Stroke speed		Max 75 stroke/min (spm)			Max 70 stroke/min (spm)		
駆動空気供給接続ポート Air supply inlet ports		2-Rc 3/8" (PT)			2-Rc 1/2" (PT)		
液体接続ポート Liquid connection ports		PTFE 3/4" (O.D 19 x I.D16mm)			PTFE 1" (O.D 25 x I.D 22mm)		
液体接触材質 Liquid contact materials		PTFE, PFA					
周囲環境温度範囲 Ambient temperature		5 ~ 50°C					
近接 センサー スイッチ Proximity switch	出力形態 Output type	NPN Output (N.O. mode)					
	パワー Power supply	DC 10~30V					

*Note.1) 最大吐出流量は室温で純水で、最大ストローク速度基準で測定

*Note.2) 1 ストローク (1 stroke) : 1回往復 (1 reciprocating motion)

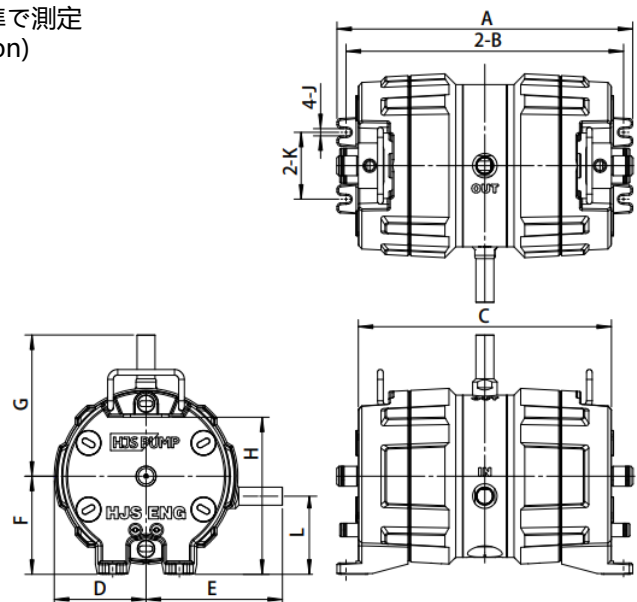
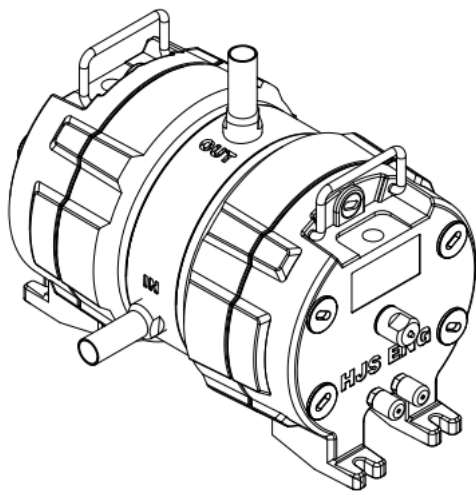

Models	A	B	C	D	E	F	G	H	J	K	L	Liquid in/out ports	Air supply ports	Weight
KP-30H	410.4	384.4	350.4	108.5	163.5	119.0	165.5	182.0	10	80	85.5	3/4"	Rc 3/8" (PT)	23 Kg
KP-60H	416.4	390.4	356.4	129.2	187.0	137.8	187.5	220.8	10	94	109.8	1"	Rc 1/2" (PT)	32 Kg

KD-30H & KD-60H

□ ダンパー (Auto Damper)

High • Medium • Room-Temperature combined Auto Damper

KD-60H



KD-30H

適用範囲 (Operating temperature)
10°C~180°C

適用ポンプ (Applied pump)
KP-30H/30M & KP-60H/60M

便利な在庫管理
Easy stock management

□ 規格 Standard Specifications

Items / Models	KD – 30H			KD – 60H		
適用ポンプ Applied pump	KP-30H / KP-30MC			KP-60H / KP-60MC		
液体温度の使用範囲 (°C) Temp. range of liquid 供給空気圧力範囲(MPa) Air supply pressure	適用ポンプ(Applied pump) : KP-30H			適用ポンプ(Applied pump) : KP-60H		
	10 ~ 50 °C	51 ~ 100°C	101 ~ 180°C	10 ~ 50°C	51 ~ 100°C	101 ~ 180°C
	0.15 ~ 0.4 MPa	0.15 ~ 0.3 MPa	0.15 ~ 0.2 MPa	0.15 ~ 0.4 MPa	0.15 ~ 0.3 MPa	0.15 ~ 0.2 MPa
※ ダンパーの供給空気圧は動作されるポンプと同じ。 Supply air to Damper at the same pressure as Pump-driven air						
液体温度の使用範囲 (°C) Temp. range of liquid 供給空気圧力範囲(MPa) Air supply pressure	適用ポンプ(Applied pump) : KP-30MC			適用ポンプ(Applied pump) : KP-60MC		
	10 ~ 50 °C	51 ~ 100°C	N/A	10 ~ 50°C	51 ~ 100°C	N/A
	0.15 ~ 0.4 MPa	0.15 ~ 0.3 MPa	N/A	0.15 ~ 0.4 MPa	0.15 ~ 0.3 MPa	N/A
※ ダンパーの供給空気圧は動作されるポンプと同じ。 Supply air to Damper at the same pressure as Pump-driven air						
駆動空気供給接続ポート Air supply inlet ports	Rc 1/8" (PT)			Rc 1/4" (PT)		
液体接続ポート Liquid connection ports	PTFE 3/4" (O.D 19 x I.D16mm)			PTFE 1" (O.D 25 x I.D 22mm)		
液体接触材質 Liquid contact materials	PTFE, PFA					
周囲環境温度範囲 Ambient temperature	5 ~ 50°C					
脈動圧力幅(MPa) Pulsation pressure width	≤ 0.06 MPa (液体粘度が 1~50mPa•sの場合) Within 0.06 MPa (in case liquid viscosity is within 1~50 mPa•s)					

KD-30H & KD-60H

□ 構成図 Structural Drawings

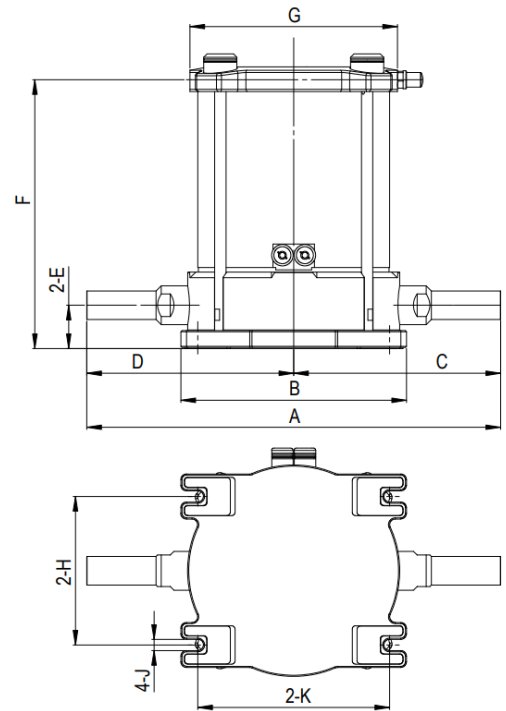
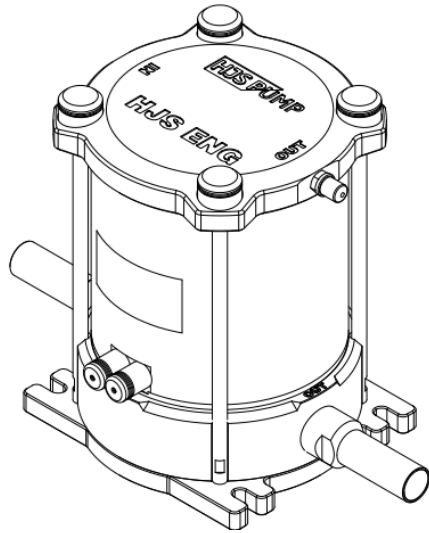

Models	A	B	C	D	E	F	G	H	J	K	Liquid in/out ports	Air supply ports	Weight
KD-30H	304.6	186	152.3	152.3	34.0	231.4	154	110	10	160	3/4"	Rc 1/8" (PT)	9 Kg
KD-60H	341.0	200	170.5	170.5	38.5	238.9	184	132	10	174	1"	Rc 1/4" (PT)	12 Kg

急速排気弁 Quick Exhaust Valve

□ ポンプリターンエアによる電磁弁の腐食防止、排気抵抗の減少

Prevent corrosion of solenoid valve by air returning from pump and reduce exhaust resistance

規格 Models	連結ポート Connection ports	適用ポンプ Applied pump
KEV-R3	Rc 3/8" (PT)	KP-30MC, KP-30H, KA-C20M, KA-C20H, KA-S25M
KEV-R4	Rc 1/2" (PT)	KP-60MC, KP-60H, KA-C40M, KA-C40H, KA-S50M



KA-C20M & KA-C40M

低脈動ポンプ (洗淨設備循環用)

Low pulsation pump (Circulation pump for Cleaning equipment)

KA-C40M



KA-C20M

適用範囲 (Operating Range)

最大流量 : 20 & 40 L/min, 適用温度 : 10°C~100°C

低脈動と安定した流量 (Low pulsation, Stable flow)

フィルター抵抗の減少 (Low filter resistance)

ポンプとダンパー一体型、設置スペースの減少

Pump & damper integration, Reduce installation space

流量 Pump Performance Curve

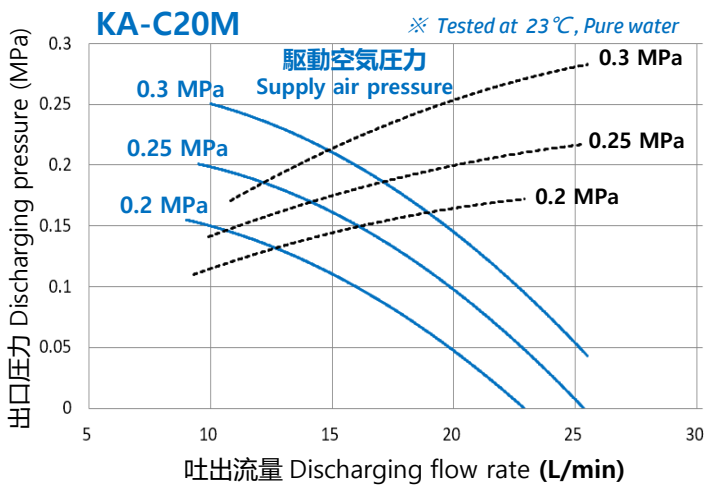

試験条件 Test conditions

- Supply air pipe size : Rc 3/8" (PT) Port (Tube O.D10 X I.D8 X 2M)
- Liquid pipe size : In port 3/4" (Tube O.D19 X I.D16)
Out port 3/4" (Tube O.D19 X I.D16)
- Test liquid : Pure water, 23°C

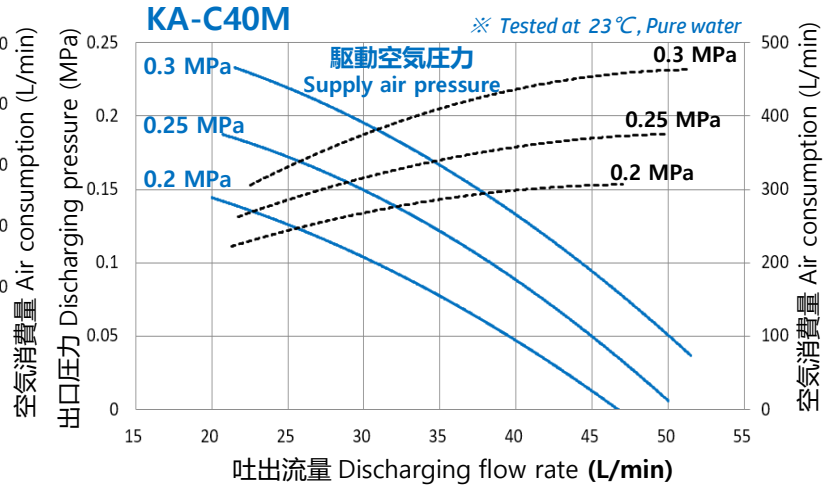

試験条件 Test conditions

- Supply air pipe size : Rc 1/2" (PT) Port (Tube O.D12 X I.D10 X 2M)
- Liquid pipe size : In port 1" (Tube O.D25 x I.D22)
Out port 1" (Tube O.D25 x I.D22)
- Test liquid : Pure water, 23°C

駆動空気圧力範囲 Driving Air Pressure Range

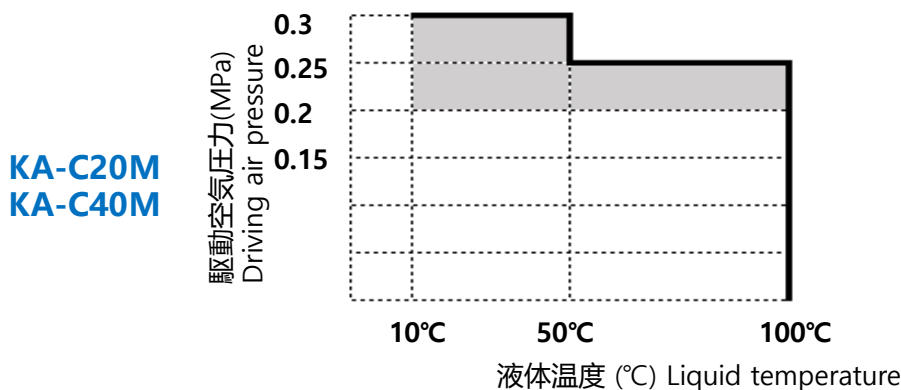

KA-C20M & KA-C40M

□ 規格 Standard Specifications

Items / Models	KA - C20M			KA - C40M		
最大吐出流量(L/min) Max. discharging flow rate	(*Note.1) 20 L/min			(*Note.1) 40 L/min		
ストローク当たり流量 Flow rate per stroke (L/stroke)	(*Note.2) 0.22 L/stroke			(*Note.2) 0.40 L/stroke		
液体温度の使用範囲 (°C) Temperature range of liquid	10 ~ 50°C	51 ~ 100°C		10 ~ 50°C	51 ~ 100°C	
駆動空気圧力範囲(MPa) Driving air pressure range	0.2 ~ 0.3 MPa	0.2 ~ 0.25 MPa		0.2 ~ 0.3 MPa	0.2 ~ 0.25 MPa	
最大許容ストローク速度 Max allowable Stroke speed	Max 105 stroke/min			Max 105 stroke/min		
駆動空気供給接続ポート Air supply inlet ports	Pump Drive Air-In ports: 2-Rc 3/8" (PT) Damping Valve Air-In port : Rc 1/4" (PT)			Pump Drive Air-In ports : 2-Rc 1/2" (PT) Damping Valve Air-In port : Rc 1/4" (PT)		
液体接続ポート Liquid connection ports	PTFE 3/4" (O.D 19 x I.D 16mm)			PTFE 1" (O.D 25 x I.D 22mm)		
液体接触材質 Liquid contact materials	PTFE, PFA					
周囲環境温度範囲 Ambient temperature	5 ~ 50°C					
近接センサースイッチ Proximity switch	出力形態 Output type	NPN Output (N.O. mode)				
	パワー Power supply	DC 12~24V				
脈動圧力幅(MPa) Pulsation pressure width	≤ 0.06 MPa (液体粘度が 1~50mPa・sの場合) Within 0.06 MPa (in case liquid viscosity is within 1~50 mPa・s)					

*Note.1) 最大吐出流量は室温で純水で、最大ストローク速度基準で測定

*Note.2) 1 ストローク (1 stroke) : 1回往復 (1 reciprocating motion)

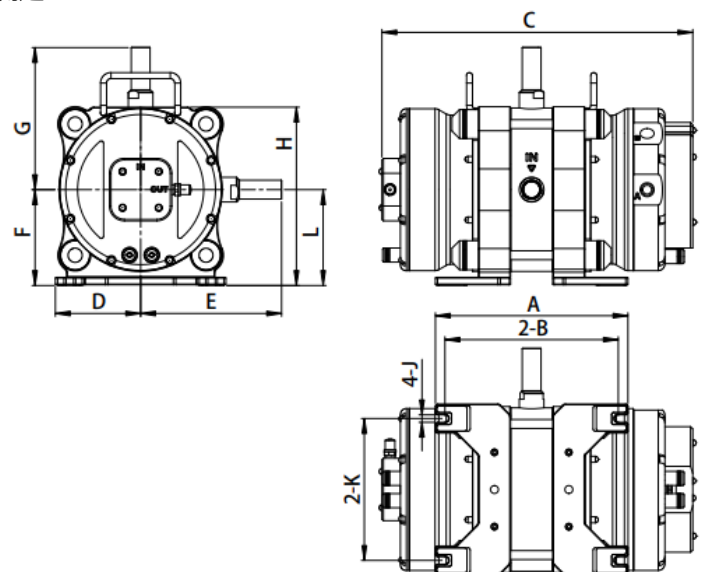
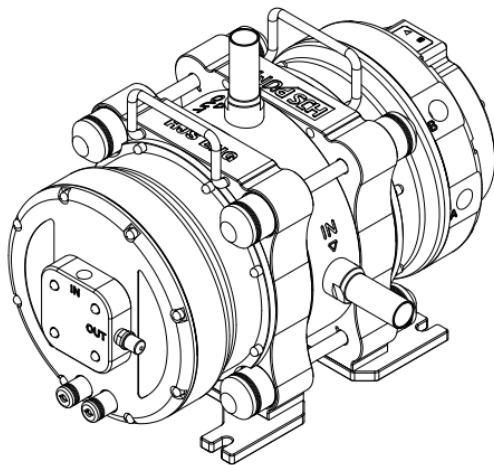

Models	A	B	C	D	E	F	G	H	J	K	L	Liquid in/out ports	Air supply ports	Weight
KA-C20M	241.0	217.0	401.6	102.5	173.5	115	173.0	215	10	166	115	In : 3/4" Out : 3/4"	Pump : Rc 3/8" (PT) Valve : Rc 1/4" (PT)	22 Kg
KA-C40M	259.6	235.6	419.1	115.0	190.0	129	191.5	240	10	191	129	In : 1" Out : 1"	Pump : Rc 1/2" (PT) Valve : Rc 1/4" (PT)	28 Kg

KA-C20H & KA-C40H

□ 低脈動ポンプ (洗浄設備循環用)

Low pulsation pump (Circulation pump for Cleaning equipment)

KA-C40H



KA-C20H

適用範囲 (Operating Range)
 最大流量 : 20 & 40 L/min, 適用温度 : 10°C~180°C

低脈動と安定した流量 (Low pulsation, Stable flow)
 フィルター抵抗の減少 (Low filter resistance)

ポンプとダンパー一体型、設置スペースの減少
 Pump & damper integration,
 Reduce installation space

□ 流量 Pump Performance Curve

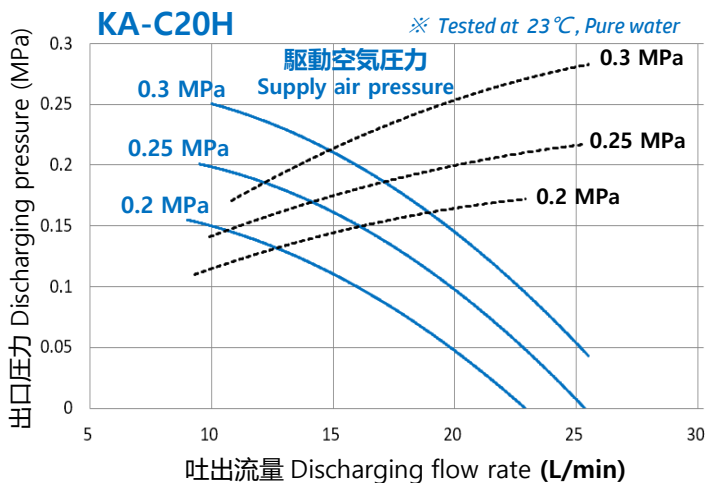

試験条件 Test conditions

- Supply air pipe size : Rc 3/8" (PT) Port (Tube O.D10 X I.D8 X 2M)
- Liquid pipe size : In port 3/4" (Tube O.D19 X I.D16)
 Out port 3/4" (Tube O.D19 X I.D16)
- Test liquid : Pure water, 23°C

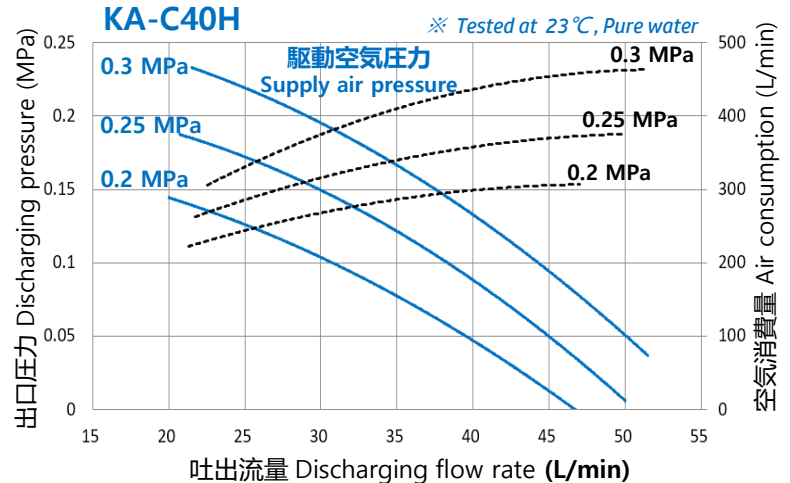

試験条件 Test conditions

- Supply air pipe size : Rc 1/2" (PT) Port (Tube O.D12 X I.D10 X 2M)
- Liquid pipe size : In port 1" (Tube O.D25 x I.D22)
 Out port 1" (Tube O.D25 x I.D22)
- Test liquid : Pure water, 23°C

□ 駆動空気圧力範囲 Driving Air Pressure Range

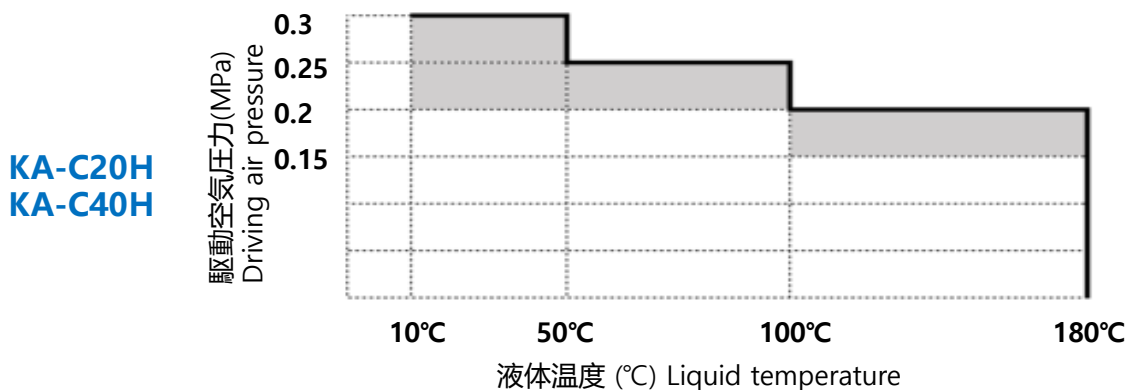

KA-C20H & KA-C40H

□ 規格 Standard Specifications

Items / Models		KA – C20H			KA – C40H		
最大吐出流量(L/min) Max. discharging flow rate		(*Note.1) 20 L/min			(*Note.1) 40 L/min		
ストローク当たり流量 Flow rate per stroke (L/stroke)		(*Note.2) 0.22 L/stroke			(*Note.2) 0.40 L/stroke		
液体温度の使用範囲 (°C) Temperature range of liquid		10 ~ 50°C	51 ~ 100°C	101 ~ 180°C	10 ~ 50°C	51 ~ 100°C	101 ~ 180°C
駆動空気圧力範囲(MPa) Driving air pressure range		0.2 ~ 0.3 MPa	0.2 ~ 0.25 MPa	0.15 ~ 0.2 MPa	0.2 ~ 0.3 MPa	0.2 ~ 0.25 MPa	0.15 ~ 0.2 MPa
最大許容ストローク速度 Max allowable Stroke speed		Max 105 stroke/min			Max 105 stroke/min		
駆動空気供給接続ポート Air supply inlet ports		Pump Drive Air-In ports: 2-Rc 3/8" (PT) Damping Valve Air-In port : Rc 1/4" (PT)			Pump Drive Air-In ports : 2-Rc 1/2" (PT) Damping Valve Air-In port : Rc 1/4" (PT)		
液体接続ポート Liquid connection ports		PTFE 3/4" (O.D 19 x I.D 16mm)			PTFE 1" (O.D 25 x I.D 22mm)		
液体接触材質 Liquid contact materials		PTFE, PFA					
周囲環境温度範囲 Ambient temperature		5 ~ 50°C					
近接 センサー スイッチ Proximity switch	出力形態 Output type	NPN Output (N.O. mode)					
	パワー Power supply	DC 12~24V					
脈動圧力幅(MPa) Pulsation pressure width		≤ 0.06 MPa (液体粘度が 1~50mPa・sの場合) Within 0.06 MPa (in case liquid viscosity is within 1~50 mPa・s)					

*Note.1) 最大吐出流量は室温で純水で、最大ストローク速度基準で測定

*Note.2) 1 ストローク (1 stroke) : 1回往復 (1 reciprocating motion)

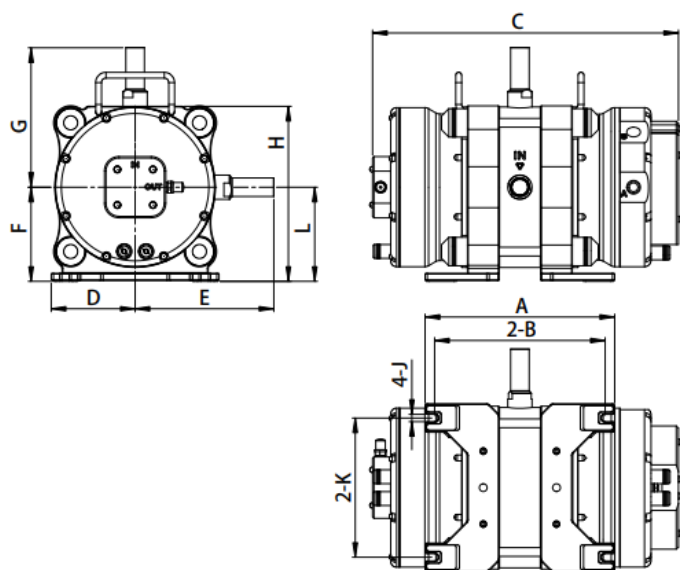
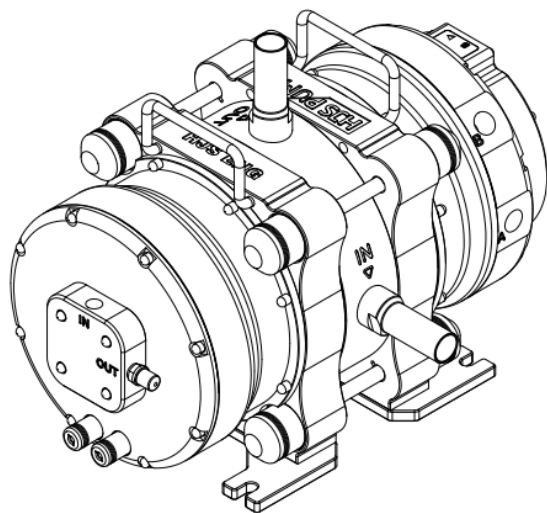

Models	A	B	C	D	E	F	G	H	J	K	L	Liquid in/out ports	Air supply ports	Weight
KA-C20H	249.0	225.0	409.6	102.5	173.5	115	173.0	215	10	166	115	In : 3/4" Out : 3/4"	Pump : Rc 3/8" (PT) Valve : Rc 1/4" (PT)	23 Kg
KA-C40H	259.6	235.6	419.1	115.0	190.0	129	191.5	240	10	191	129	In : 1" Out : 1"	Pump : Rc 1/2" (PT) Valve : Rc 1/4" (PT)	28 Kg

KA-S25M & KA-S50M

低脈動ポンプ (様々なケミカル移送用、Slurry等)

Low pulsation pump (For various chemical supply system, Slurry etc.)

KA-S50M



KA-S25M

应用范围 (Operating Range)

最大流量 : 25 & 50 L/min, 適用温度 : 10°C~100°C

低脉动及稳定的流量 (Low pulsation, Stable flow)

过滤阻力降低 (Low filter resistance)

泵和阻尼器一体型, 减少安装空间

Pump & damper integration,

Reduce installation space

流量 Pump Performance Curve

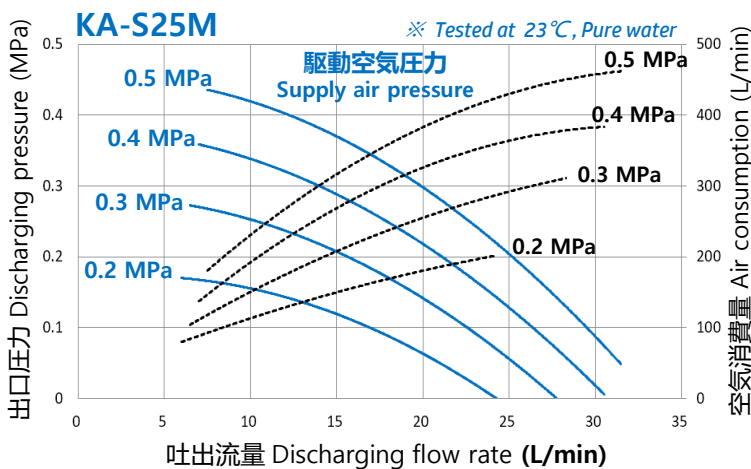

試験条件 Test conditions

- Supply air pipe size : Rc 3/8" (PT) Port (Tube O.D10 X I.D8 X 2M)
- Liquid pipe size : In port 1" (Tube O.D25 X I.D22)
Out port 3/4" (Tube O.D19 X I.D16)
- Test liquid : Pure water, 23°C

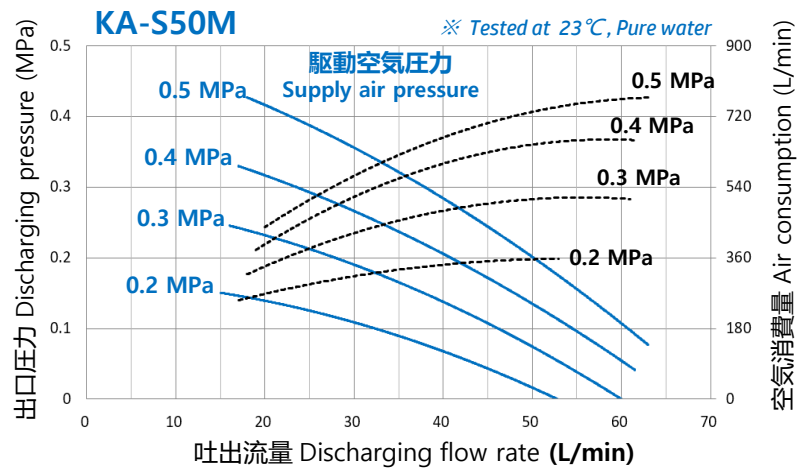

試験条件 Test conditions

- Supply air pipe size : Rc 1/2" (PT) Port (Tube O.D12 X I.D10 X 2M)
- Liquid pipe size : In port 1+1/2" (Tube O.D38 X I.D34)
Out port 1" (Tube O.D25 X I.D22)
- Test liquid : Pure water, 23°C

駆動空気圧力範囲 Driving Air Pressure Range

KA-S25M
KA-S50M

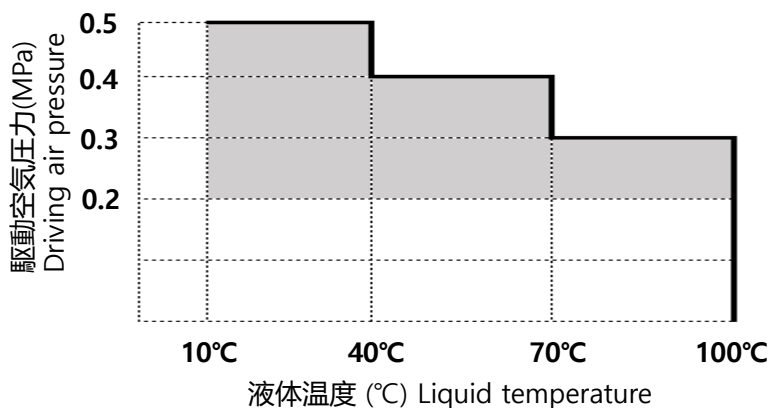

KA-S25M & KA-S50M

□ 規格 Standard Specifications

Items / Models		KA – S25M			KA – S50M		
最大吐出流量(L/min) Max. discharging flow rate		(*Note.1) 25 L/min			(*Note.1) 50 L/min		
ストローク当たり流量 Flow rate per stroke (L/stroke)		(*Note.2) 0.22 L/stroke			(*Note.2) 0.46 L/stroke		
液体温度の使用範囲 (°C) Temperature range of liquid		10 ~ 40°C	41 ~ 70°C	71 ~ 100°C	10 ~ 40°C	41 ~ 70°C	71 ~ 100°C
駆動空気圧力範囲(MPa) Driving air pressure range		0.2 ~ 0.5 MPa	0.2 ~ 0.4 MPa	0.2 ~ 0.3 MPa	0.2 ~ 0.5 MPa	0.2 ~ 0.4 MPa	0.2 ~ 0.3 MPa
最大許容ストローク速度 Max allowable Stroke speed		Max 115 stroke/min			Max 115 stroke/min		
駆動空気供給接続ポート Air supply inlet ports		Pump Drive Air-In ports : 2-Rc 3/8" (PT) Damping Valve Air-In port : Rc 1/4" (PT)			Pump Drive Air-In ports : 2-Rc 1/2" (PT) Damping Valve Air-In port : Rc 1/4" (PT)		
液体接続ポート Liquid connection ports		- In port : PTFE 1" (O.D 25 x I.D 22mm) - Out port : PTFE 3/4" (O.D 19 x I.D 16mm)			- In port : PTFE 1+1/2" (O.D 38 x I.D 34mm) - Out port : PTFE 1" (O.D 25 x I.D 22mm)		
液体接触材質 Liquid contact materials		PTFE, PFA					
周囲環境温度範囲 Ambient temperature		5 ~ 50°C					
近接 センサー スイッチ Proximity switch	出力形態 Output type	NPN Output (N.O. mode)					
	パワー Power supply	DC 12~24V					
脈動圧力幅(MPa) Pulsation pressure width		≤ 0.06 MPa (液体粘度が 1~50mPa・sの場合) Within 0.06 MPa (in case liquid viscosity is within 1~50 mPa・s)					

*Note.1) 最大吐出流量は室温で純水で、最大ストローク速度基準で測定

*Note.2) 1 ストローク (1 stroke) : 1 回往復 (1 reciprocating motion)

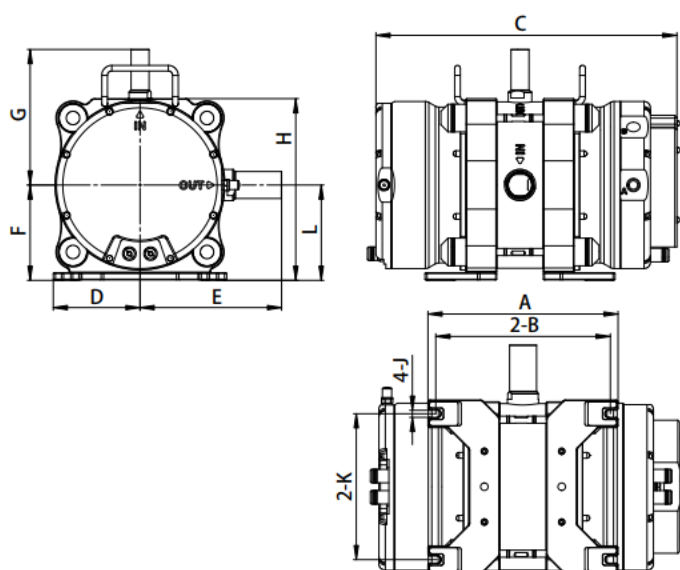
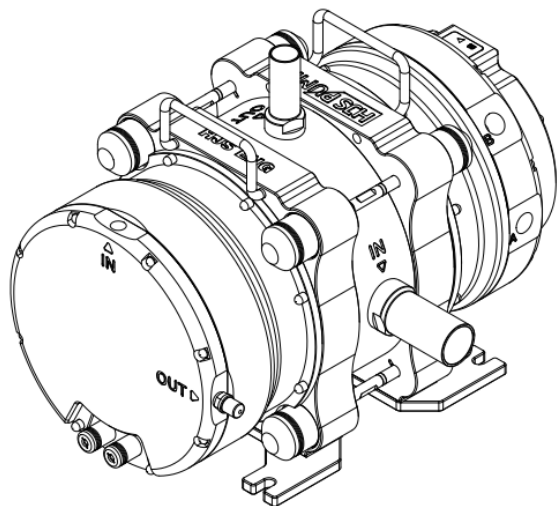

Models	A	B	C	D	E	F	G	H	J	K	L	Liquid in/out ports	Air supply ports	Weight
KA-S25M	249.0	225.0	405.5	102.5	180.5	115	173.0	215	10	166	115	In : 1" Out : 3/4"	Pump : Rc 3/8" (PT) Valve : Rc 1/4" (PT)	24 Kg
KA-S50M	268.6	244.6	425.3	122.5	200.0	135	191.5	257	10	206	135	In : 1+1/2" Out : 1"	Pump : Rc 1/2" (PT) Valve : Rc 1/4" (PT)	33 Kg

注意事項 Precautions

1. 構成図 (Structural Drawings)

本製品は量産中に一部変更されることがありますので、実際に販売されている製品と本カタログの内容に若干の差がある場合があります。

(This product may be partially changed during mass production, so there may be some differences between the actual product being sold and the contents of this catalog.)

2. 圧縮空気 (Compressed air)

ポンプの近くの位置で圧力を下げた後、圧縮空気を供給してください。圧縮空気は、使用する化学物質や温度に制限があります。

(Supply the compressed air after reducing pressure at the nearest position of the pump. The compressed air has limitations as to chemicals and temperature to be used.)

3. 使用注意液体 (Chemicals to be handled with care)

もし製品が以下の化学溶液に使用される場合は、当社に連絡してください。

使用条件によっては、非標準規格の製品が必要になる場合があります。

(If the product is used in the following chemical solutions, please contact us. Depending on the conditions of use, non-standard products may be required.)

- 1) 塩酸(HCL)、硝酸(HNO₃)などの高透過性化学物質(*Highly permeable chemicals*) : 腐食防止規格必要(*Corrosion-proof*)
(Highly permeable chemical including hydrochloric acid (HCL), nitric (HNO₃) acid, etc : Corrosion-proof is required.)
- 2) 溶剤系溶液 (Solvent) : 防爆規格必要 (*Explosion-proof*)
(Solvent : Explosion-proof is required.)
- 3) ヒドラジン (Hydrazine) 、発煙硫酸 (Fuming sulfuric acid) 、およびストリッパー(Stripper) などの高活性化学物質
(Highly reactive chemicals including hydrazine, fuming sulfuric acid and stripper.)

Company Website

Korean (한국어)



www.hjseng.com

Chinese (中文版)



www.hjseng.com

韩国 (Korean Office) :

HJS Eng CO.,LTD

7-5, Gokhyeon-ro 855 beon-Gil, Mohyeon-eup, Cheoin-gu, Yongin-si, Gyeonggi-do, Korea 17033

TEL : +82) 031-745-2425 / FAX : +82) 031-322-2413



中国 (Chinese Office) :

HJS Eng (Shandong) Co.,Ltd.

Shuangdao Road 369-7# 5F(West), Hi-Tech IDZ, Weihai, Shandong Province, China

TEL : +86) 0631-565-1898 / FAX : +86) 0631-565-1897